



INSTALLATION INSTRUCTIONS

Read installation instructions first before installing. Check parts to ensure that no damage has occurred during transit and that no parts are missing. Also check the diameter of the pipe and the range marked on the tapping sleeve to ensure you have the proper size.

Style STS 420

Step 1 • Clean pipe surface, particularly in the gasket sealing area.

Step 2 • Remove bolts and separate sleeve halves.

Step 3 • Lubricate gasket and pipe surface with a suitable gasket lubricant.

Step 4 • Place the outlet half of sleeve onto the pipe and move into position. Do not slide outlet half of sleeve around pipe.

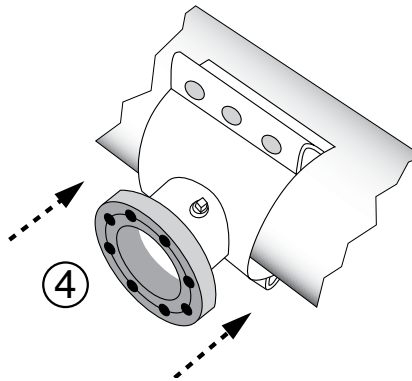

Step 5 • Bring the back half of sleeve into position and insert the bolts.

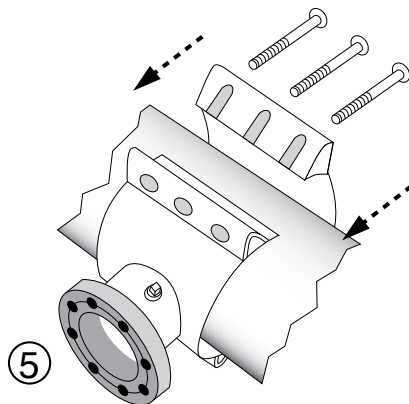

Step 6 • Install nuts and washers and tighten uniformly to a minimum 75 ft-lbs. torque. The gap between sleeve halves should be equal on both sides when the nuts are fully torqued.

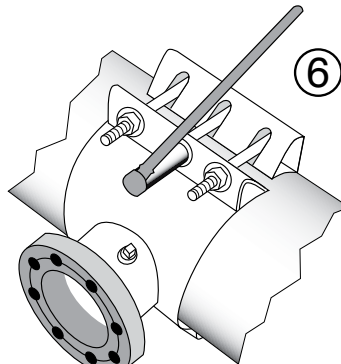

Step 7 • Bolt tapping valve to flange.

The inside of the flange accepts the tapping valve locator. The flange gasket, which is glued in place, is the only gasket needed. Block or otherwise support valve.

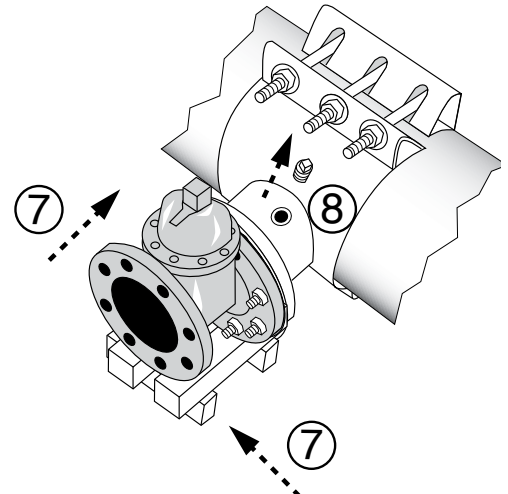

Step 8 • Remove test plug and pressure test assembly to determine a tight joint. Test at pressure up to 1.25 times the pressure in the pipeline or to the maximum shown in the table (below) whichever is less.

Pipe Size	Flange Size	Working Pressure	Test Pressure
6" - 24"	3"-8" Cls D	250 psi	312 psi
6" - 24"	10"-12" Cls D	200 psi	225 psi
6" - 24"	10"-12" Cls E	250 psi	312 psi
30" - 36"	3"-36" Cls D	150 psi	187 psi
42"	3"-24" Cls D	150 psi	187 psi
42"	30"- 42" Cls D	100 psi	125 psi
> 42"	3" and larger	100 psi	125 psi

3" - 12" Outlet has flange gasket

Step 9 • When it is ascertained that the sleeve is leak-tight, proceed with the tapping operation.

Step 10 • Tapping equipment must be supported so that its weight is not supported by the sleeve.

Style STS 420 Fabricated Stainless Steel Tapping Sleeve

PRECAUTIONS

1. Check diameter of pipe to make sure you are using the correctly sized sleeve.
2. Clean pipe to remove as much dirt and corrosion as possible from the surface.
3. Make sure no foreign materials stick to the gasket as it is brought around the pipe, nor become lodged between gasket and pipe as nuts are tightened.
4. Avoid loose fitting wrenches, or wrenches too short to achieve proper torque.
5. Keep threads free of foreign material to allow proper tightening.
6. Bolts are often not tightened enough when a torque wrench is not used. Take extra care in this situation to make sure proper tightening occurs.
7. Install tapping sleeve with outlet in the direction of the branch pipe. Do not spin or rotate tapping sleeve on pipe.
8. Pressure test for leaks before tapping pipe.
9. Backfill and compact carefully around sleeve.
10. Caution, when reinstalling parts with stainless steel hardware there may be a loss in pressure holding ability due to worn or damaged threads during the original installation.
11. For personal safety reasons, do not use a compressible fluid (such as air) to check for water tightness.

COMMON INSTALLATION PROBLEMS

- | | |
|--|---|
| 1. Not enough torque on bolts. | 5. Not using the proper size sleeve for the pipe. |
| 2. Rocks or debris cutting gasket. | 6. Not using thrust block or other form of restraint. |
| 3. Dirty threads on bolts or nuts. | 7. Spinning or rotating tapping sleeve on the pipe. |
| 4. Allowing tapping sleeve to support the cantilever load of the valve, tapping machine or pipe. | |

NOTE: Tapping sleeves are designed for sealing purposes only, not structural support or restraint.