



INSTALLATION INSTRUCTIONS

Read installation instructions first before installing. Check parts to ensure that no damage has occurred during transit and that no parts are missing. Also check the diameter of the pipe and the range marked on the tapping sleeve to ensure you have the proper size.

Style SST-MJ

Stainless Steel Tapping Sleeve with Mechanical Joint Outlet For sizes 8" x 8" & larger

WARNING: Plastic lubricating washers must be used (see Step 5)

Step 1 • Before installing tapping sleeve, clean pipe thoroughly, removing all dirt, rock, scale and foreign material in area where tapping sleeve is to be installed. A suitable lubricant should be used on rough surface pipe (Iron and A/C) to assure proper seal.

Step 2 • Remove nuts and lifter bars from bolts, being careful not to lose washers.

Step 3 • Place outlet-half of sleeve on pipe and move into position, being careful not to fold under the gasket.

Step 4 • Bring back half of sleeve into position, making sure bolts are located between mating receiver lugs on the sleeve outlet half. Check gasket edges along sleeve top and bottom halves to be sure they overlap and are not folded under. Also check that the armor is between the back half and pipe.

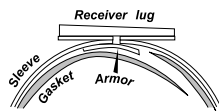

Step 5 • Replace lifter bars first, and then washers and nuts. Make sure that the plastic washer goes on **FIRST**, followed by the stainless steel washer and then the nut. It is important that the washers are installed in this order.

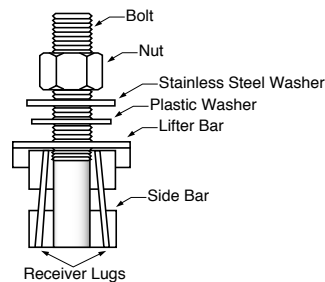

Step 6 • Well-tightened nuts are important to ensure a full-circle seal. Tighten nuts, starting with center bolts, alternating on either side of the sleeve. Gap between sleeve halves on either side should be the same when nuts are fully torqued.

Tighten nuts evenly in 25 ft.-lb. increments.

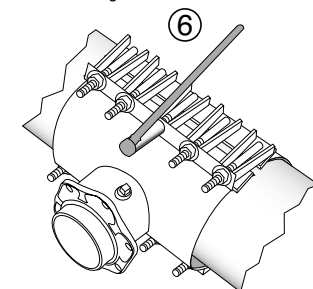

Nom. Pipe Diameter	Torque
8" through 30"	minimum 75 ft.-lbs.

Note:

60 ft.-lbs. = 12" wrench w/ 60lb. force applied
75 ft.-lbs. = 12" wrench w/ 75 lb. force applied

For best results, wait at least 10 minutes, then retighten.

Step 7 • Coat MJ gasket with approved lubricant. Place gasket on sleeve outlet and slide down to base.

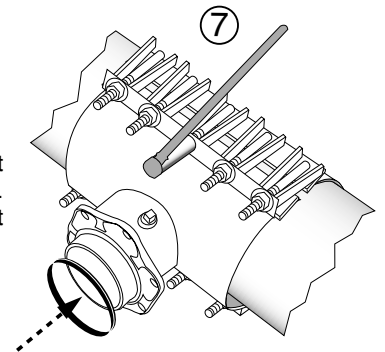

Step 8 • Block or otherwise support valve. Bolt MJ valve to MJ outlet and tighten evenly to a minimum of 90 ft.-lbs. Make sure the valve is in proper alignment by checking to see that the distance between flange faces on all sides is equal.

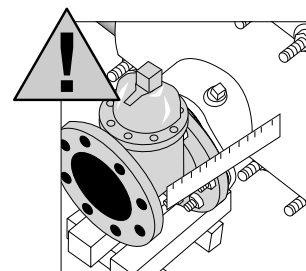
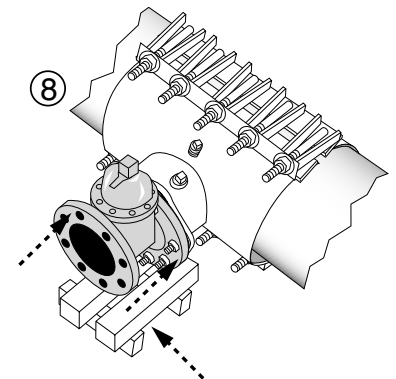

NOTE: Be sure to measure the gap between flange faces all the way around the valve, to ensure valve flange and tapping sleeve flange are parallel.

Installation Instructions continued on back

INSTALLATION INSTRUCTIONS

Style SST-MJ

For sizes 8" x 8" & larger (continued from front)

Step 9 • Remove test plug and connect test apparatus to tapping sleeve assembly. Test at pressure up to 1.25 times the pressure in the pipeline or to the maximum in the table (below), whichever is less. If assembly leaks, check bolts to be sure the nuts have been torqued to the recommended torque value, and then retest assembly.



NOTE: Make sure the cutter will fit through the valve

Step 10 • Block or otherwise support the tapping machine during the tap, then be sure and support the pipe being connected to the valve.

Pipe Size	Working Pressure	Test Pressure
4"-8"	250	312 psi
10"-24"	200	300 psi
26"-30"	150	188 psi

PRECAUTIONS

1. Check diameter of pipe to make sure you are using the correctly sized sleeve.
2. Clean pipe to remove as much dirt and corrosion as possible from the surface.
3. Make sure no foreign materials stick to the gasket as it is brought around the pipe, nor become lodged between gasket and pipe as nuts are tightened.
4. Avoid loose fitting wrenches, or wrenches too short to achieve proper torque.
5. Keep threads free of foreign material to allow proper tightening.
6. Bolts are often not tightened enough when a torque wrench is not used. Take extra care in this situation to make sure proper tightening occurs.

NOTE: Breaking of plastic lubricating washers and dimpling of the washer plates (lifter bars) is normal and does not affect the performance of the sleeve. In fact, lack of lifter bar deformation indicates inadequate nut tightening.

7. Install tapping sleeve with outlet in the direction of the branch pipe. Do not spin or rotate tapping sleeve on pipe.
8. Be extra careful when installing valve that valve and sleeve flanges are parallel.
9. Pressure test for leaks before tapping pipe.
10. Backfill and compact carefully around sleeve.
11. When reinstalling parts with stainless steel hardware there may be a loss of pressure holding ability due to worn or damaged threads during the original installation.
12. For personal safety reasons, do not use a compressible fluid (such as air) to check for water tightness.

COMMON INSTALLATION PROBLEMS

- | | |
|--|---|
| 1. Not enough torque on bolts. | 6. Not using thrust block or other form of restraint. |
| 2. Rocks or debris cutting gasket. | 7. Spinning or rotating tapping sleeve on the pipe. |
| 3. Dirty threads on bolts or nuts. | 8. Valve and tapping sleeve flanges not parallel. |
| 4. Allowing tapping sleeve to support the cantilever load of the valve, tapping machine or pipe. | |
| 5. Not using the proper size sleeve for the pipe. | |

NOTE: Tapping sleeves are designed for sealing purposes only, not structural support or restraint.