



# INSTALLATION INSTRUCTIONS

Read installation instructions first before installing. Check parts to ensure that no damage has occurred during transit and that no parts are missing. Also check the diameter of the pipe and the range marked on the tapping sleeve to ensure you have the proper size.

## Style FTS 419 Fabricated Steel Tapping Sleeve

**Step 1** • Clean pipe surface, particularly in the gasket sealing area.

**Step 2** • Remove bolts and separate sleeve halves.

**Step 3** • Lubricate gasket and pipe surface with a suitable gasket lubricant.

**Step 4** • Place the outlet half of sleeve onto the pipe and move into position. Do not slide outlet half of sleeve around pipe.

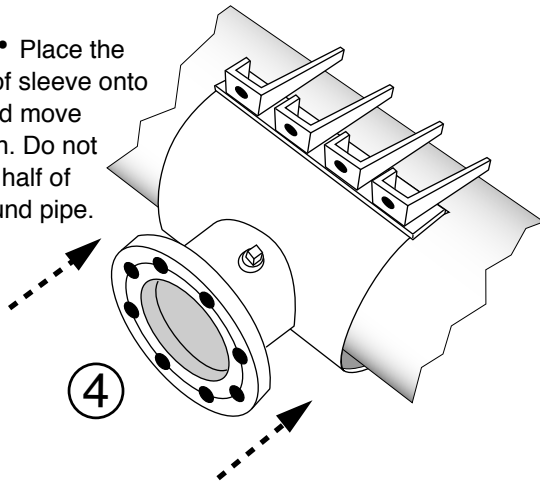

**Step 5** • Bring the back half of sleeve into position and insert the bolts.

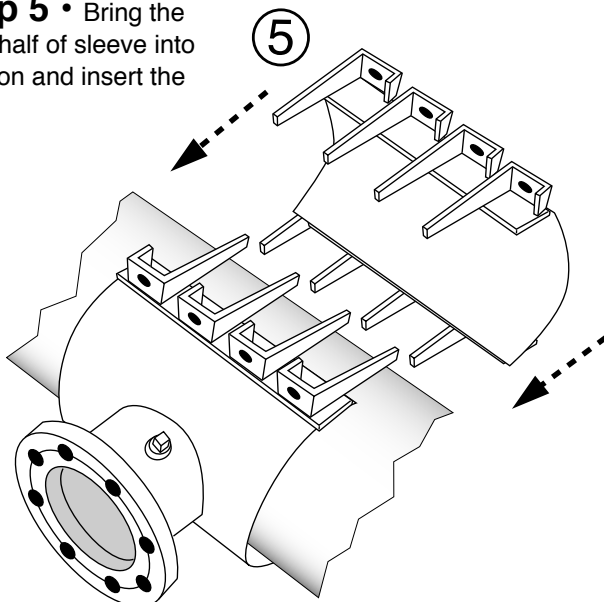

**Step 6** • Tighten bolts uniformly to 45-50 ft-lbs. torque. The gap between sleeve halves should be equal on both sides when the nuts are fully torqued.

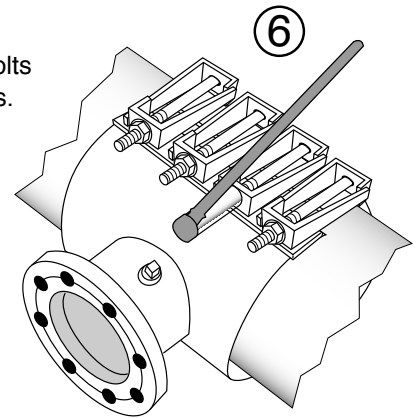

**Step 7** • Install tapping valve. Tapping valve must be supported.

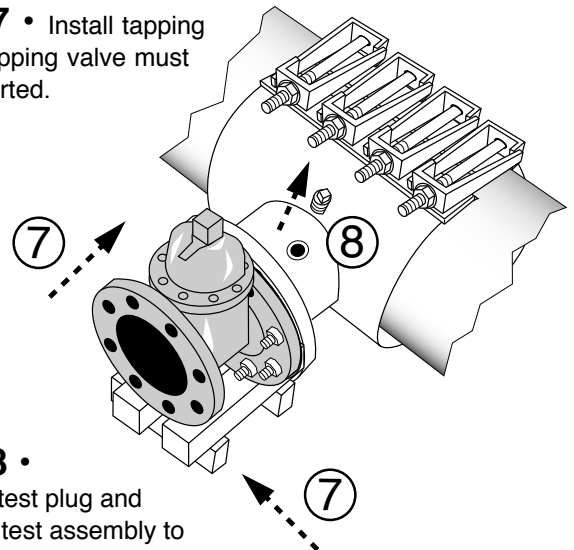

**Step 8** • Remove test plug and pressure test assembly to determine a tight joint. Test at pressure up to 1.25 times flange rating. For AWWA Class D flanges, sizes 4-12 inch, maximum working pressure of 175 psi, and up to 220 psi for test.

**Step 9** • When it is ascertained that sleeve is leak-tight, proceed with the tapping operation.

**Step 10** • Tapping equipment must be supported so that its weight is not supported by the sleeve.

## Style FTS 419 Fabricated Steel Tapping Sleeve

### PRECAUTIONS

1. Check diameter of pipe to make sure you are using the correctly sized sleeve.
2. Clean pipe to remove as much dirt and corrosion as possible from the surface.
3. Make sure no foreign materials stick to the gasket as it is brought around the pipe, nor become lodged between gasket and pipe as nuts are tightened.
4. Avoid loose fitting wrenches, or wrenches too short to achieve proper torque.
5. Keep threads free of foreign material to allow proper tightening.
6. Bolts are often not tightened enough when a torque wrench is not used. Take extra care in this situation to make sure proper tightening occurs.
7. Install tapping sleeve with outlet in the direction of the branch pipe. Do not spin or rotate tapping sleeve on pipe.
8. Pressure test for leaks before tapping pipe.
9. Backfill and compact carefully around sleeve.
10. Caution, when reinstalling parts with stainless steel hardware there may be a loss in pressure holding ability due to worn or damaged threads during the original installation.
11. For personal safety reasons, do not use a compressible fluid (such as air) to check for water tightness.

### COMMON INSTALLATION PROBLEMS

- |  |   |
|--|---|
| 1. Not enough torque on bolts.   | 5. Not using the proper size sleeve for the pipe.     |
| 2. Rocks or debris cutting gasket.   | 6. Not using thrust block or other form of restraint. |
| 3. Dirty threads on bolts or nuts.   | 7. Spinning or rotating tapping sleeve on the pipe.   |
| 4. Allowing tapping sleeve to support the cantilever load of the valve, tapping machine or pipe. |   |

**NOTE: Tapping sleeves are designed for sealing purposes only, not structural support or restraint.**